

2018 LEXION combine operations

CLAAS of America Inc



Company: CLAAS of America Inc.
Address: 8401 South 132nd Street
Omaha, NE 68138
Phone: 402-861-1000
Fax: 402-861-1003
Website: www.claas.com

Images and content are intended to cover ALL features and options available on 2018 LEXION Combines. Content may vary on each machine configuration. The conditions and configurations recommended in this presentation are intended to cover most, but not all, situations from a theoretical viewpoint. For this reason, descriptions are intentionally kept generic. Keep in mind that this is NOT a “a substitute for the owners manual, but only a supplement to provide recommendations and tips to help optimize performance on a LEXION combine.

LEXION Model: 780 – 670
Build Year: 2017
Effective Date: 4/1/2018
Last Revision: 3/22/2018

<u>1. Feederhouse</u>	5
<u>2. Pre-concave / APS</u>	14
<u>3. Main concave / Threshing cylinder</u>	21
<u>4. Impeller</u>	25
<u>5. Separation (rotors / walkers)</u>	27
<u>6. Preparation floor</u>	31
<u>7. Cleaning (JET STREAM / Standard Cleaning)</u>	32
<u>8. Residue management</u>	42
<u>9. Maintenance</u>	48
<u>10. Slug removal</u>	72
<u>11. Settings and adjustments</u>	78

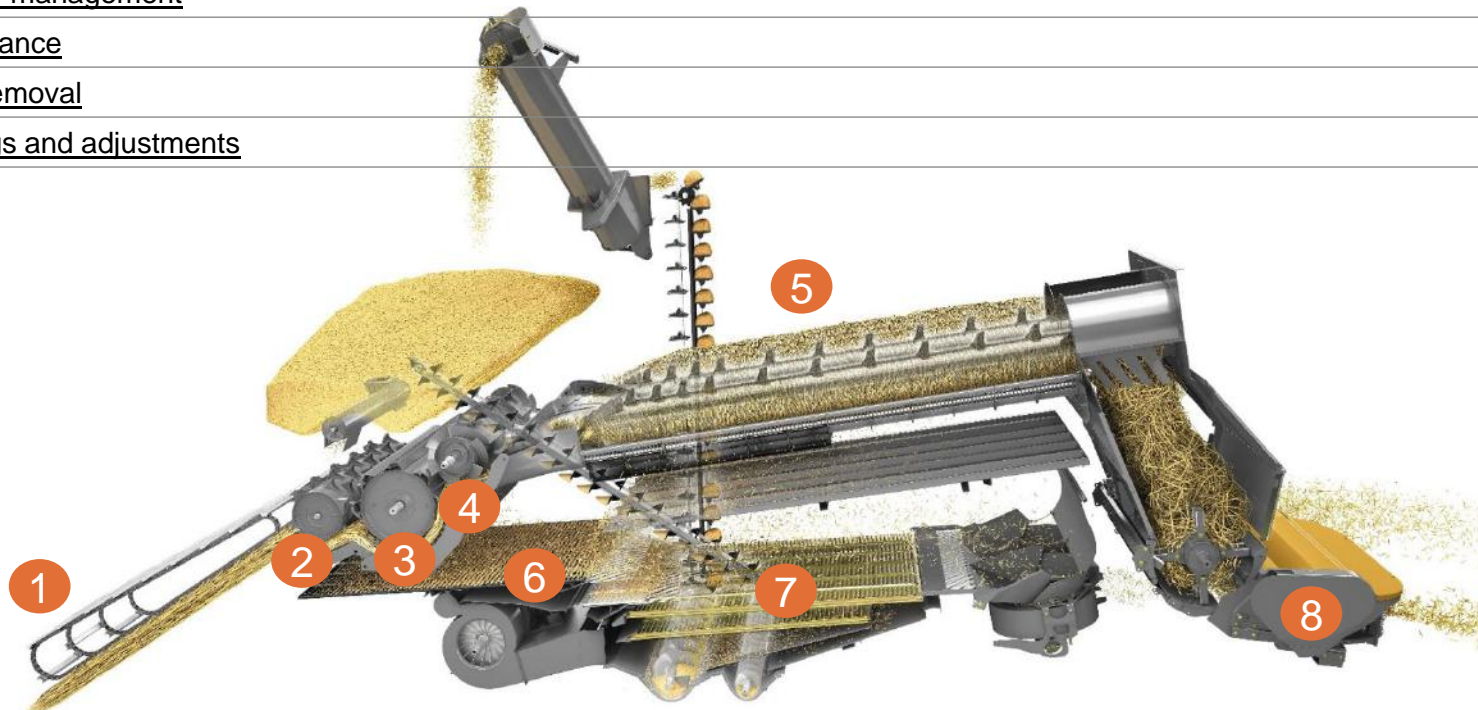

Side draper speed

Too fast

- Crop flow concentrated in center
- Cannot utilize full combine capacity (width)

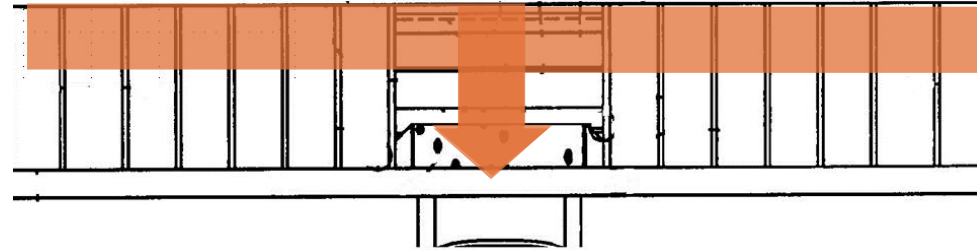

Optimal speed

- + Smooth, wide feed
- + Good capacity to keep up with incoming crop

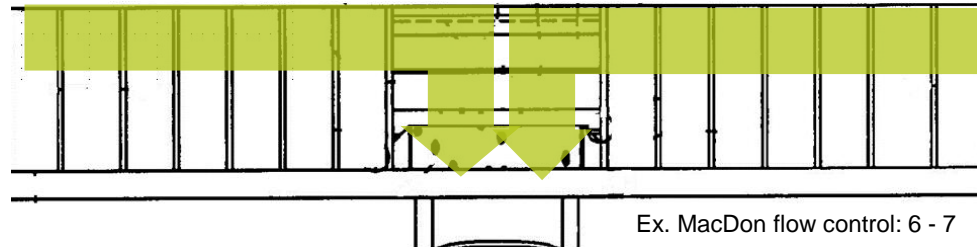

Too slow

- Chance of wrapping under side draper belts
- Chance of pinching crop in side-wall

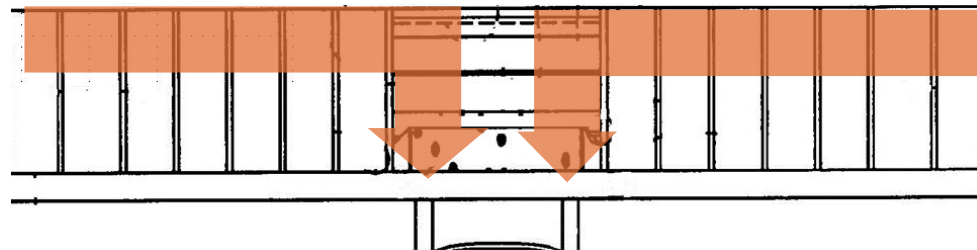

*Improper belt speed can create additional drag on power, increasing engine load, reducing ground speed and can prematurely wear out the impeller

To access the flow control valve, pull bottom of compartment cover (A) to open.

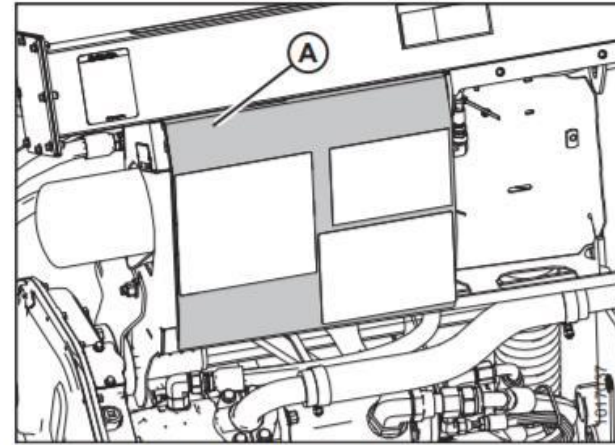

Figure 3.75: Hydraulic Compartment Cover

The flow control valve (A) has settings from 0–9 on the barrel to indicate the draper speed. The flow control valve is factory-set to 6 which should be sufficient for normal crop feeding.

To change the draper speed, shut down the combine and rotate the flow control valve dial to adjust the control.

Refer to one of the following for recommended draper speed settings:

- [3.6.2 Header Settings, page 41](#)
- [3.6.3 Optimizing Header for Straight Combining Canola, page 45](#)

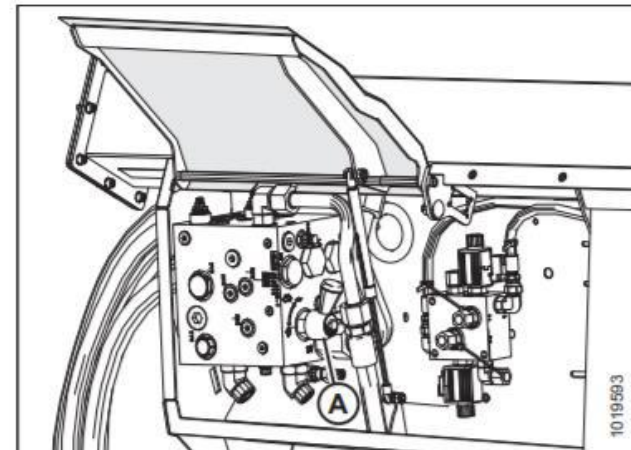
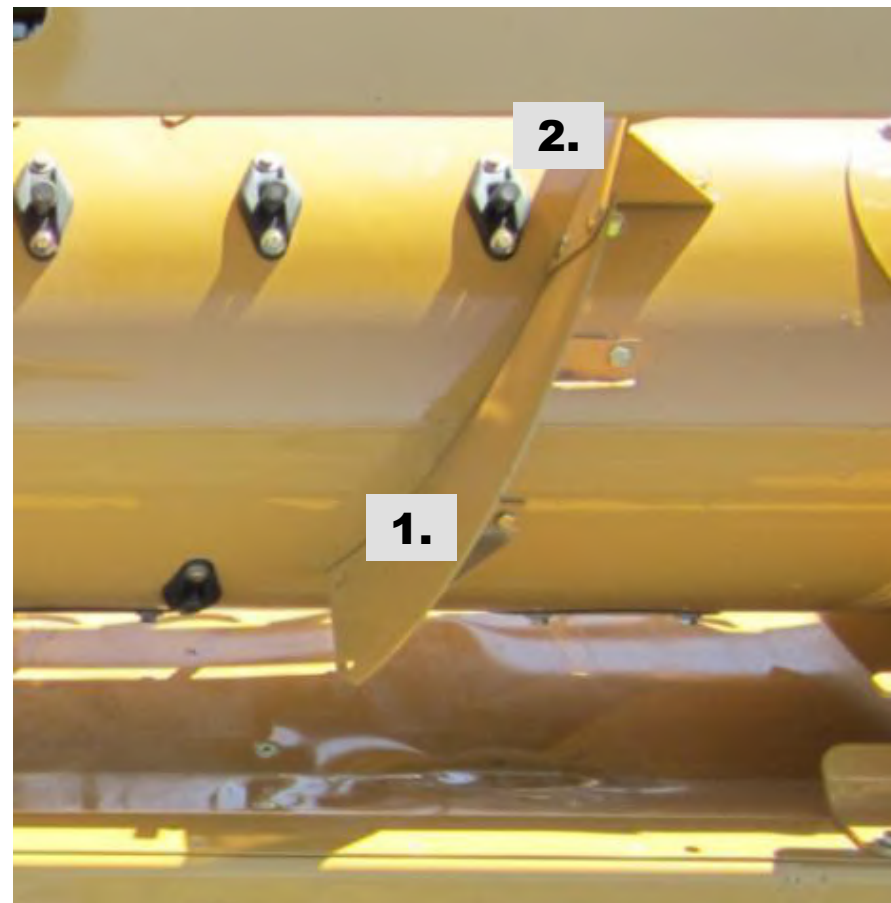

Figure 3.76: Flow Control Valve (Parts Removed for Clarity)

Flighting extensions

- Match width of feederhouse and conditions
- Wide feederhouse should have few/no extensions



Speed

High speed (420rpm)

- + Best feeding in small grains
- + Tough to thresh crops
- + Best for draper headers
- Increases aggressiveness of feederhouse
- Potential inconsistent feeding (small swathed crops)

Mid-speed (330-400rpm)

- + Good speed for corn & soybeans
- + Moderate to thresh crops
- Moderate aggressiveness, not ideal for pulse crops

Low speed (<320rpm)

- + Most gentle speed range
- + Easy to thresh / pulse crops
- Can potentially limit capacity in small grains

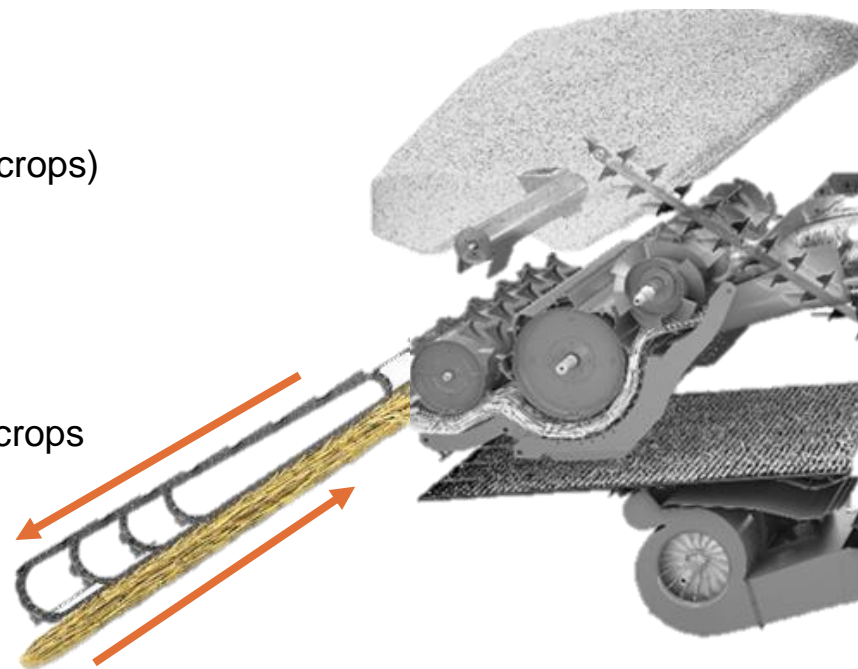

*Feederhouse speed also dictates header speed. Most adjustments will affect header performance more than combine performance.

Drum position

Drum up: wider intake of crop

- + Better feeding in corn/sunflowers
- + Less aggressive
- Less consistent feed in small grains

Drum down: narrow intake of crop

- + Better feeding in small grains
- + More aggressive for tough conditions
- Increased shelling/threshing action

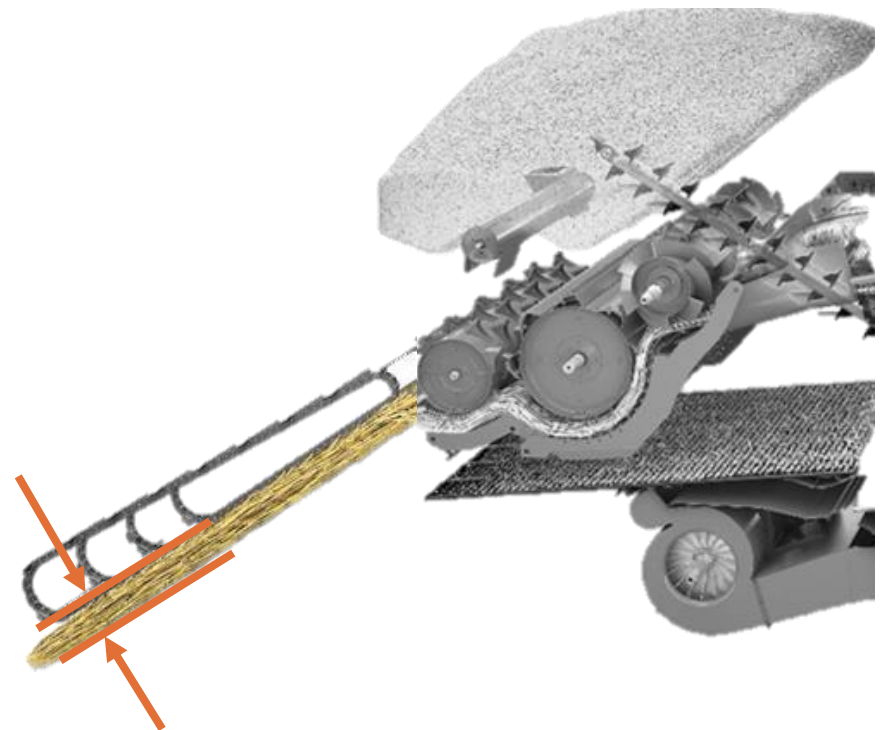

HP Feederhouse

Too far forward

- + Aggressive cut angle
- + Knife may cut closer to the ground
- Increased risk of damaging knives or dirt intake

Too far backward

- + Less likely to intake rocks
- + Retain slightly more crop
- May not get under lodged crop well enough
- May not get close enough cut to the ground

For best results:

- When in doubt, start at 0-degrees
- Corn heads: 1-3 degree fwd
- Flex heads 0-2 degree back

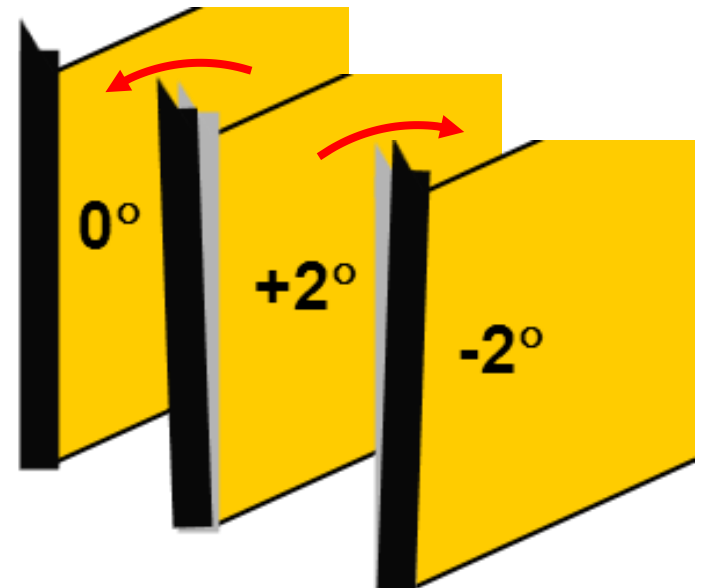

Graduated lever (2008 – 2012)

HP faceplate angle example

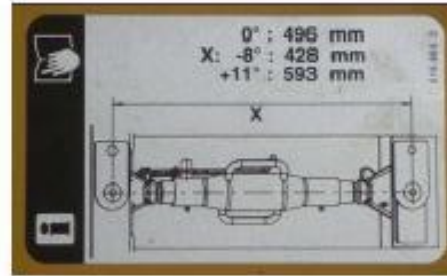
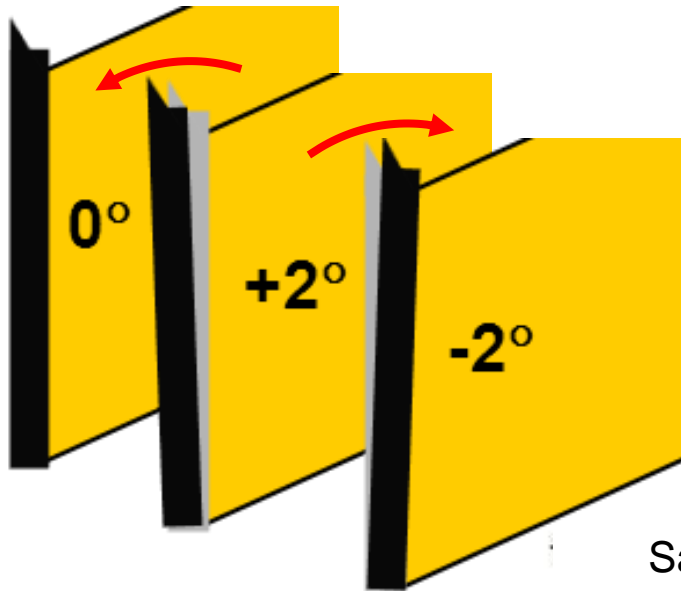

1 degree interval

2 degree intervals

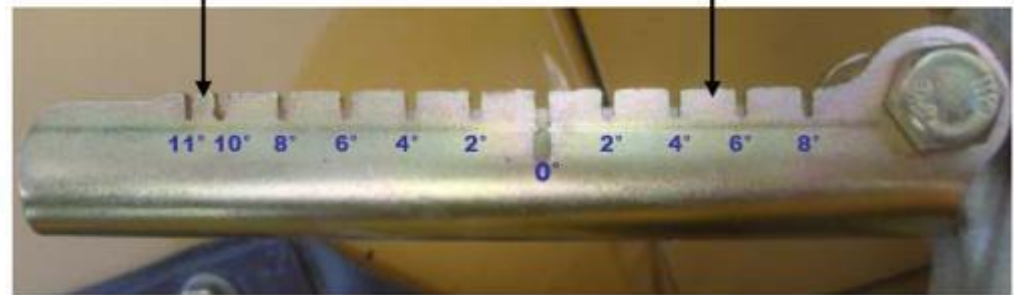

Saw-tooth indicator (2004 – 2006)

For best results:

- When in doubt, start at 0-degrees
- Corn heads: 1-3 degree fwd
- Flex heads 0-2 degree back

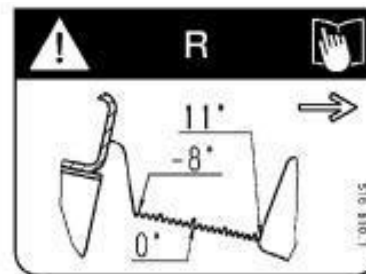

Dis-awning plates

Open

- + Pre separation (up to 30%)
- + Decreased potential grain damage
- Potential increased chaff load on cleaning shoe

Closed

- + More aggressive threshing
- + Decreased chaff on cleaning shoe
- Potential for increased grain damage

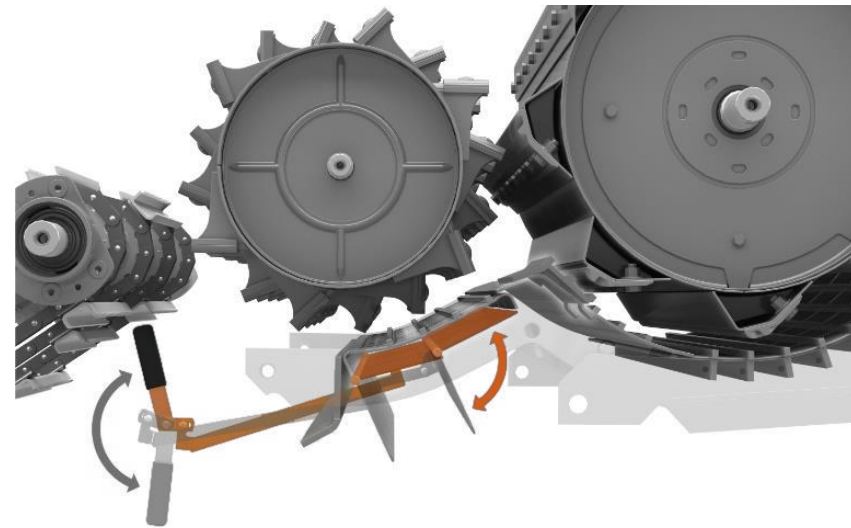

APS grates

1. Key stock 2 3 4

- + More aggressive threshing
- Increased damage
- Increased chaff on cleaning shoe

2. Smooth 1 5 6

- + Less aggressive threshing
- + Decreased chaff on cleaning shoe
- Potential for increased grain damage

3. Large opening 5 6 7

- + More pre-separation (more capacity)
- + Large grain can be pre-separated
- More chaff on cleaning shoe

4. Small opening 1 2

- + Less chaff on cleaning shoe
- + Small kernels can be pre-separated
- Large material cannot pass (including grain)

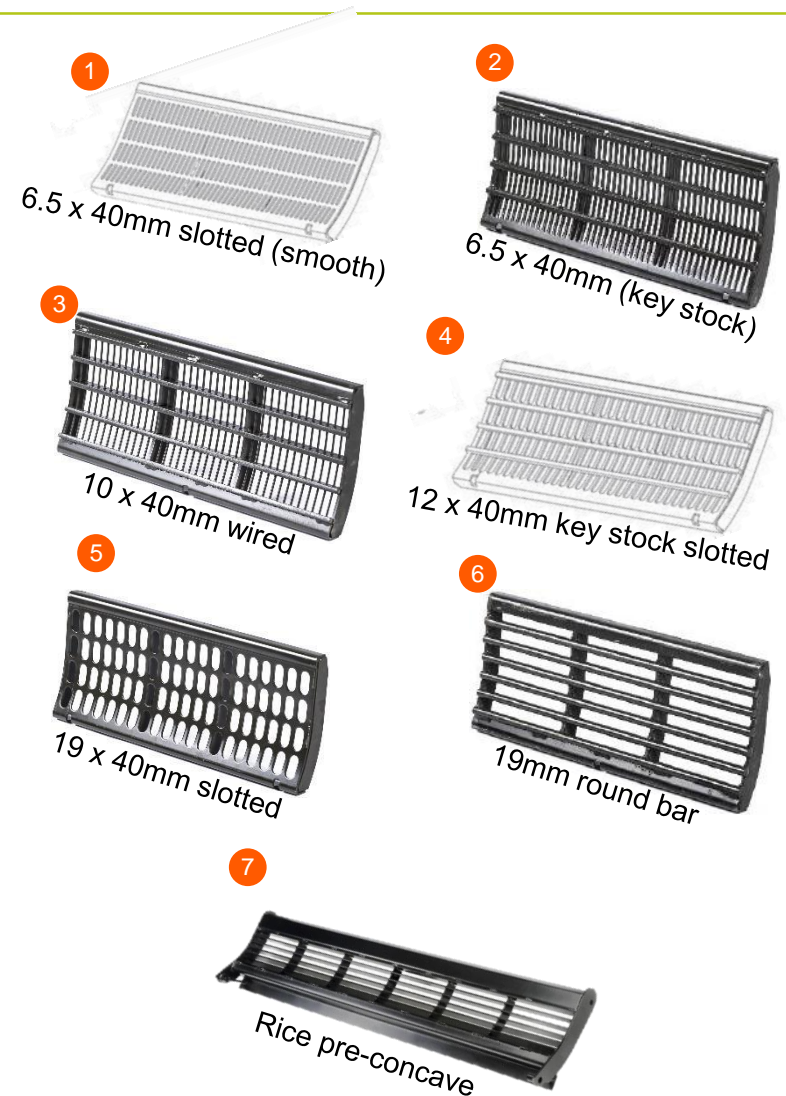

10x40mm keystick

Medium size hole keystick grate for tough threshing crops

Effective in:

- + Barley
- + Canola
- + Edible beans
- + Flax
- + “Green-stem” Soybeans
- + Lentils
- + Malted barley
- + Milo
- + Oats
- + Peas
- + Rice
- + Soybeans
- + Wheat

Not recommended for use large grain crops

- Potential for increased grain damage
- Potential higher chaff load on cleaning shoe



Part	Standard chassis	Wide chassis	Quantity
10x40mm keystick	777 238.1	777 249.1	3

12x40mm keystone

Largest size hole keystone grate for tough threshing crops

Effective in:

- + Barley
- + Canola
- + Edible beans
- + “Green-stem” Soybeans
- + Lentils
- + Malted barley
- + Milo
- + Oats
- + Peas
- + Rice
- + Soybeans
- + Wheat

Not recommended for use large grain crops

- Potential for increased grain damage
- Potential higher chaff load on cleaning shoe
- Potential higher chaff load on cleaning shoe

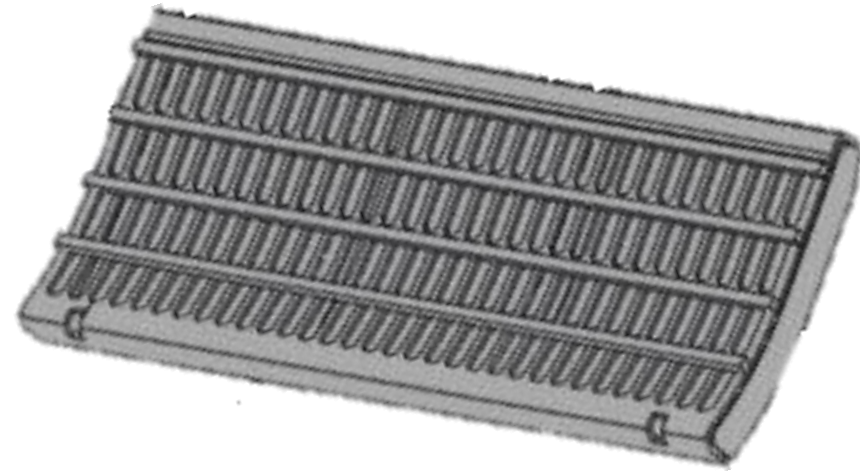

Part	Standard chassis	Wide chassis	Quantity
12x40mm keystone	91022328	91022481	3

19x40 slotted

Gentle threshing smooth grate with large opening for pre-separation

Effective in:

- + Corn
- + Edible beans
- + “High moisture” Corn
- + Milo
- + Peas
- + Popcorn
- + Soybeans
- + Sunflowers

Not recommended for use in small grains or tough threshing crops

- Potential higher chaff load on cleaning shoe
- Tough to thresh crop may not be threshed



Part	Standard chassis	Wide chassis	Quantity
19x40mm slotted	757 441.0	757 439.0	3

Round bar

Gentle threshing smooth grate with large opening for pre-separation.

Effective in:

- + Corn
- + Edible beans
- + “High moisture” Corn
- + Milo
- + Peas
- + Popcorn
- + Soybeans
- + Sunflowers

Not recommended for use in small grains or tough threshing crops

- Potential higher chaff load on cleaning shoe
- Tough to thresh crop may not be threshed



Part	Standard chassis	Wide chassis	Quantity
Round bar	1 809 068.0	1 809 067.0	3

APS additions

1. Main concave filler strips

- + Holds crop in concave longer
- + Increases threshing action
- Limits separation in main concave

2. Intensive threshing segments (ITS)

- + Increases threshing action at front of main concave
- + Increases wrap on threshing cylinder
- Potential for increased grain damage
- Potential increased chaff load on cleaning shoe

3. Pre-concave back slope blanking plate

- + Helps remove white caps
- + Increases threshing action
- Less open area – potential for lower capacity in large-kernel crops

*Recommended use

- Corn combines used to harvest wheat or small grains
- All components can be added individually, to improve sample quality and performance

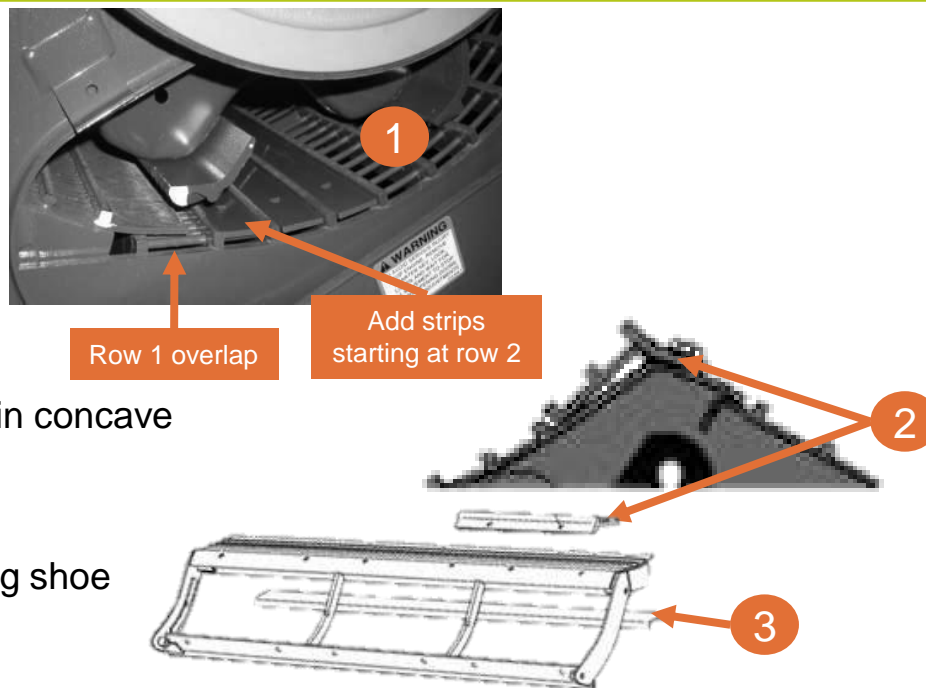

		Part	Standard chassis	Wide chassis
Pre-concave	Intensive threshing segments (ITS)		735 629.0 (2)	752 543.0 (3)
	Pre-concave back slope blanking plate		CL9995210	CL9995220
Main concave	Filler strips		356 728.0	356 729.0
	Clover strips		754 836.1	736 568.1

Configurations

Round bar

- + Most open area
- + Least aggressive (ideal for corn)
- Can struggle to thresh tougher small grains
- Filler strips cannot be installed

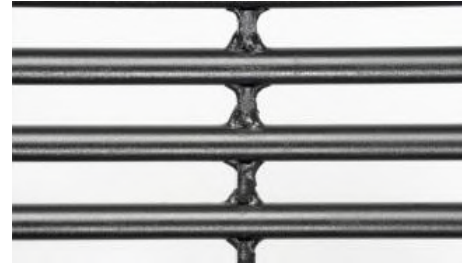

N18

- + Key stock makes it more aggressive
- + Filler strips can be installed for small grains
- + Good open area for high capacity
- Potential for higher trash load on cleaning shoe in small grains
- Potential for lower capacity in corn



N7/18

- + Most aggressive
- + Less trash on cleaning shoe in small grains
- Less open area – potential for lower capacity in large-kernel crops

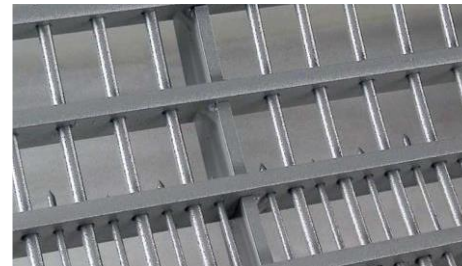

*These are *not* interchangeable on short notice

Concave gap

1. Tight (7-12mm)

- + More aggressive threshing
- Increased damage possible
- Increased chaff load

2. Medium (13-20mm)

- + Moderate threshing
- Moderate chaff load
- Moderate damage possible

3. Open (20+mm)

- + Gentle threshing
- Reduced chaff load
- Reduced damage possible

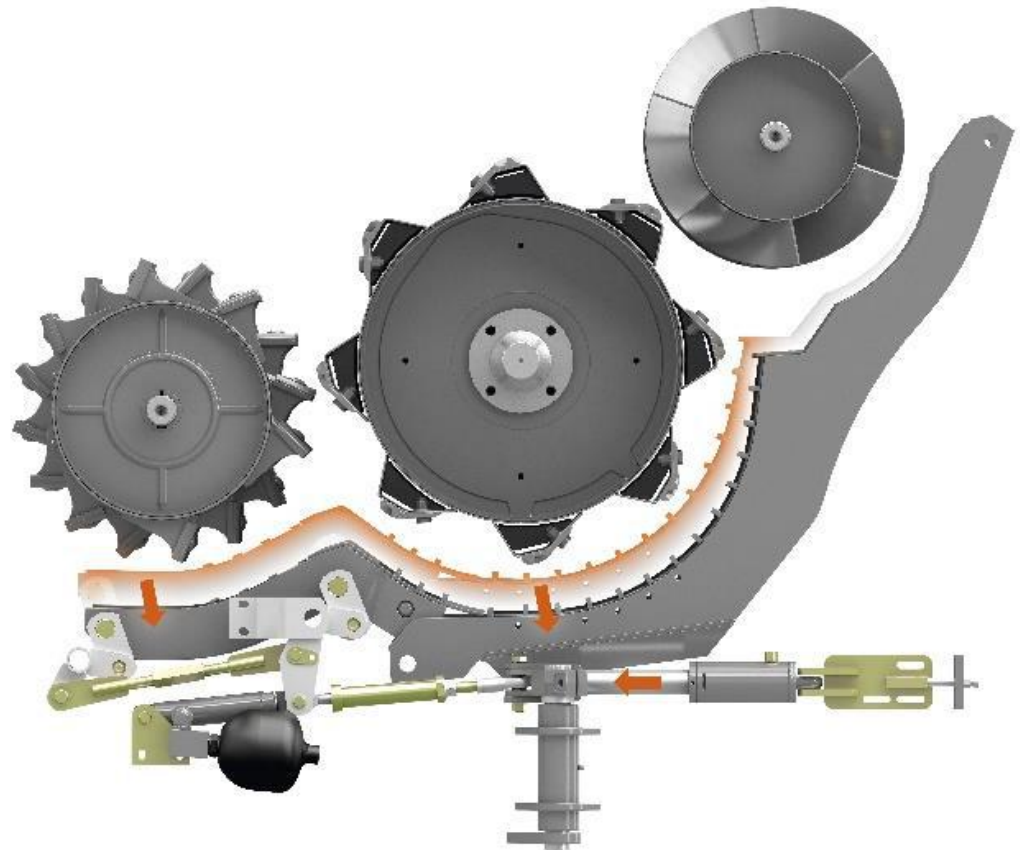

Threshing speed

1. High

- + Most aggressive threshing
- Increased damage possible
- Increased chaff on cleaning shoe

2. Medium

- + Moderate threshing
- Moderate chaff load
- Moderate damage possible

3. Low

- + Gentle threshing
- Reduced chaff load
- Reduced damage possible

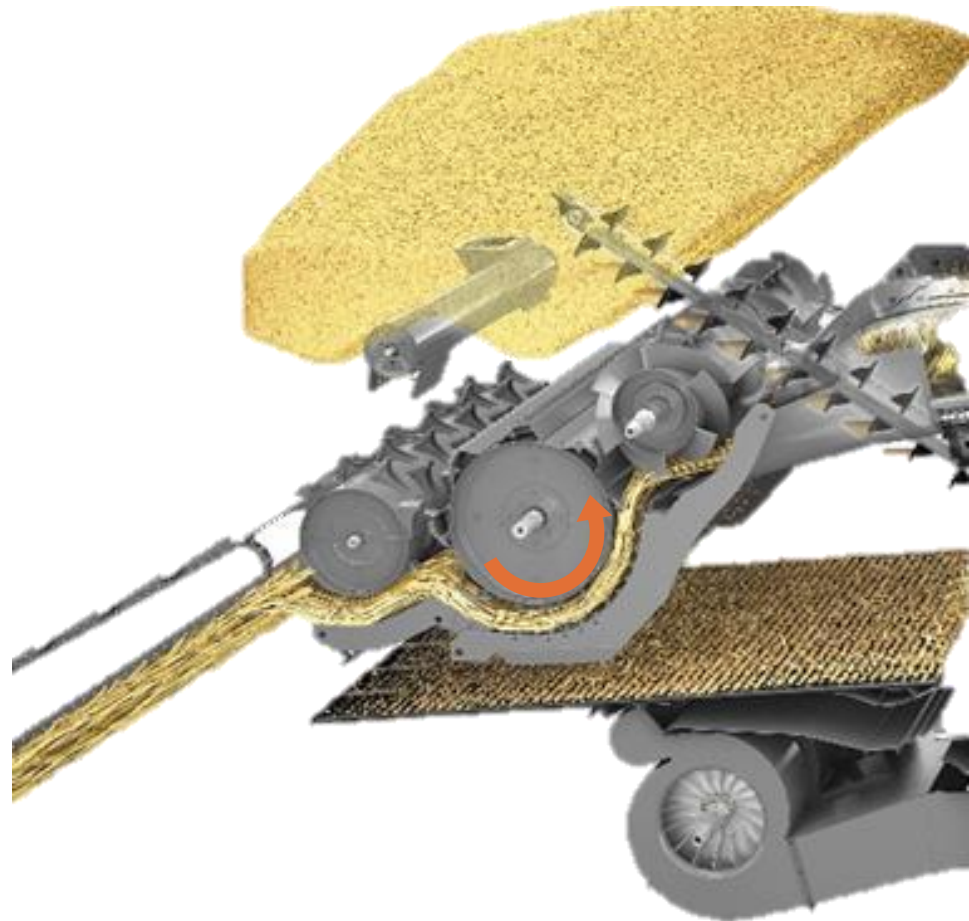

High / low range

1. High range (small grains, canola, soybeans, tough threshing crops)

- + 400 - 1050rpm
- + Increased threshing action

2. Low range (corn, easy-threshing crops)

- + 180 - 450rpm
- + Higher torque than high range (400-450rpm)

If working near this speed, switch to LOW range for best performance

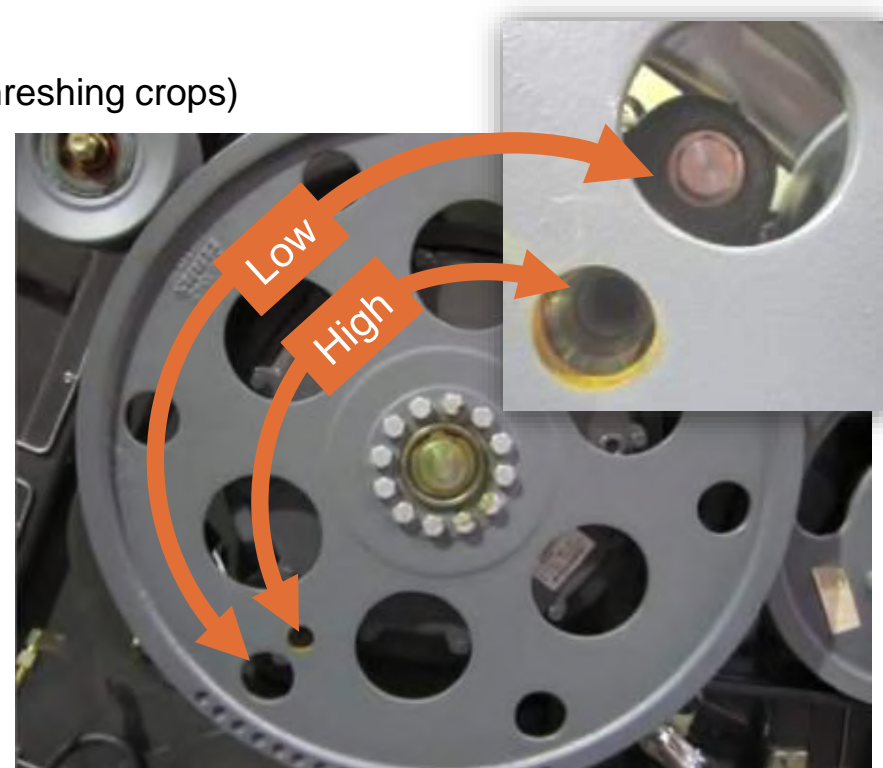
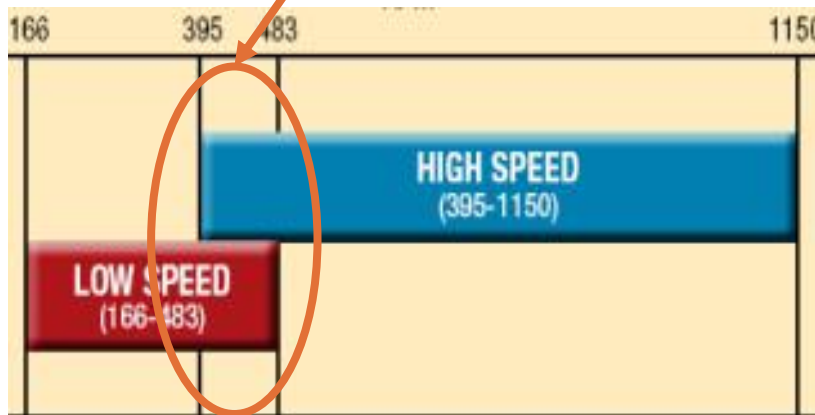

V-plates (aka “Dakota Kit”)

- + Improved crop flow into/through the rear impeller
- + Higher feeding efficiency in tough-to-thresh conditions
- + Allows threshing cylinder to be run at lower speed in delicate crops
- + Less potential grain damage
- No dis-advantages

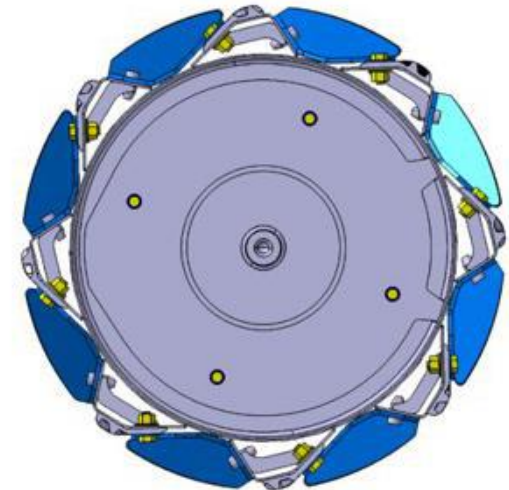
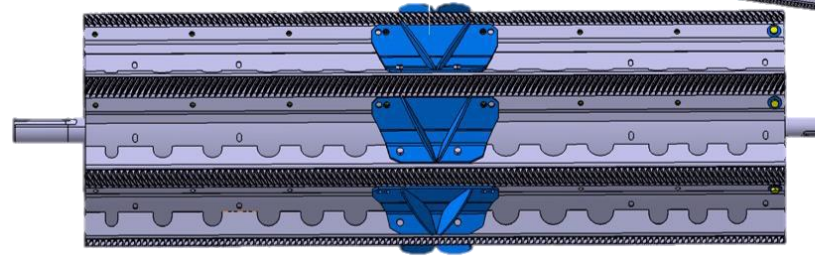
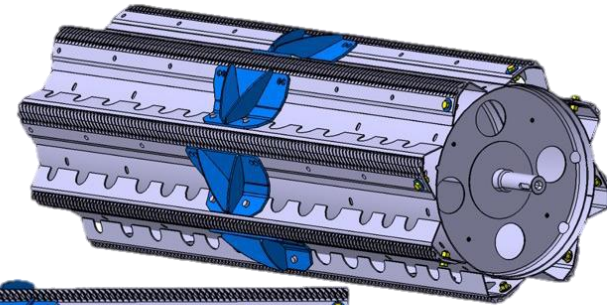

- 700 series
 - Installtion
 1. Access through door located under cab/above feederhouse
 2. Attaches using center two rasp bar bolts
 - Part number
 - **1816 934.0**
- 500 series
 - Installtion
 1. Access through door located under cab/above feederhouse
 2. Replace existing blanking plate with v-plate blanking plate
 - Part number
 - Standard chassis: **1816 946.0**
 - Wide chassis: **1816 941.0**

Rear impeller wear strips

Check wear prior to starting harvest.

- Excessive wear (if center blades are worn more than .5 in. compared to the outside blades) can lead to:
 - Back-feeding
 - Increased engine loads

- If difference in wear is .5 in. or more, impeller should be re-flighted

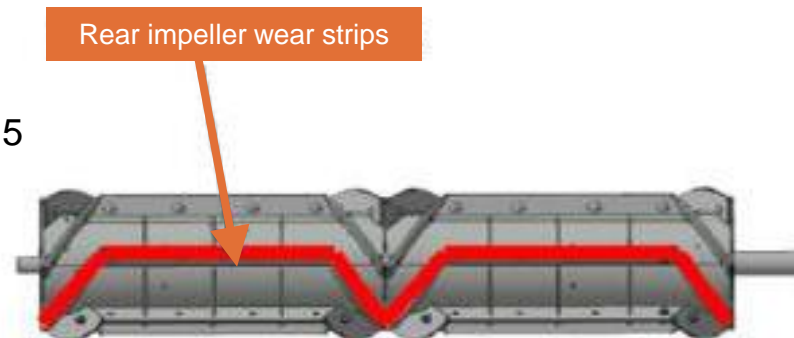

		Part	Standard duty (5mm)	Heavy duty (8mm)
Standard chassis	Chevron		777 615.0	1809 844.0
	Flat vein		777 629.0	1809 848.0
Wide chassis	Chevron		777 615.0	1809 844.0
	Flat vein		777 639.0	1809 846.0

Serrated impeller wear strips

- + Can be installed on center of rear impeller and divider between rotors
- + Provides a slicing action that can cut through tough stems
- + Improves crop flow efficiency
- + To be used in tough-to-thresh crop with ropey stem crops

Component A can only be installed if component B is

Component B can be installed alone

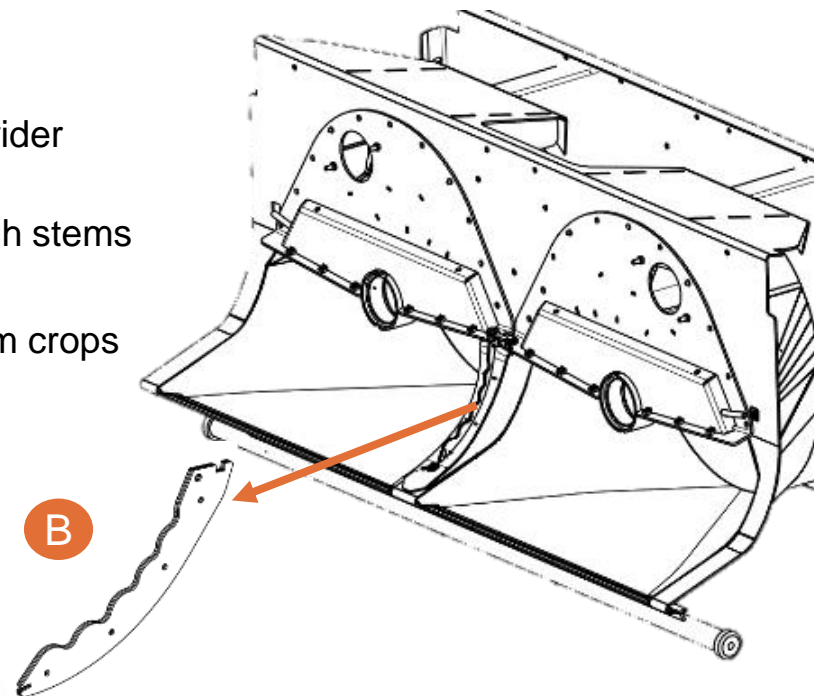
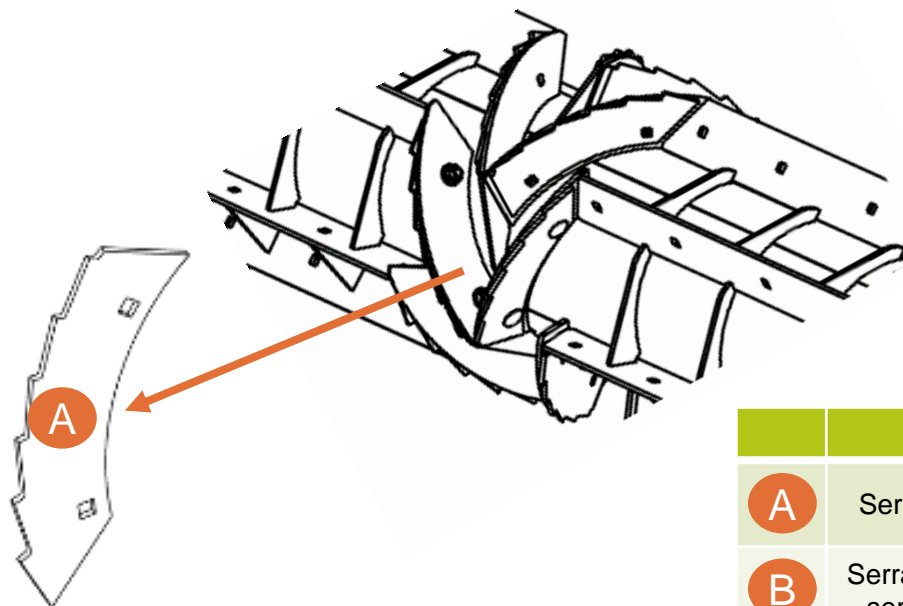

	Part	Standard chassis	Wide chassis
A	Serrated impeller wear strips	1498 884.0	1498 884.0
B	Serrated impeller wear strips + serrated rotor intake divider	1498 882.0	1498 883.0

Rotor speed

1. High speed = high separation force (centripetal)
 - + High separation force (lots of straw / material)
 - Potential to limit capacity in high-yield crops (“auger effect”)
2. Low speed = low separation force
 - + Increases capacity in high-yield crops
 - Low separation force can prevent grain from separating

In straw/stem crops, typically at least +100 rpm over the threshing speed is recommended

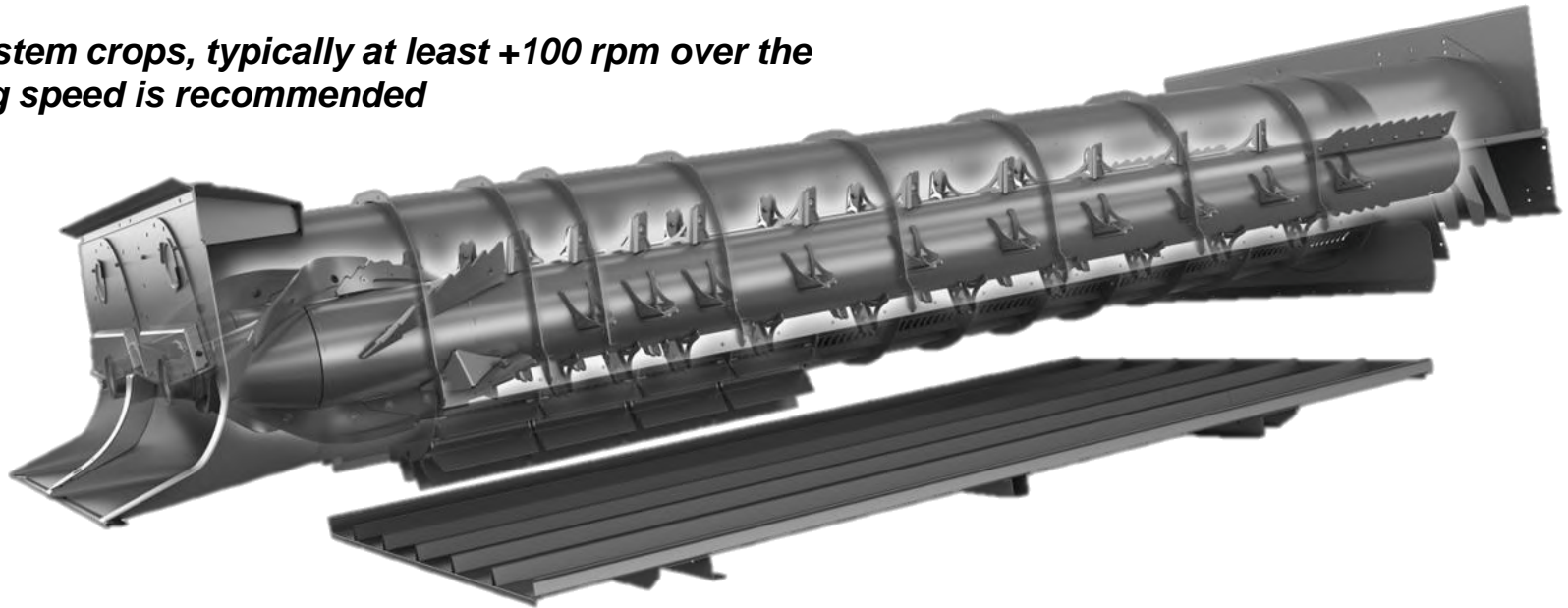

Threshing vs Separation Gradual acceleration

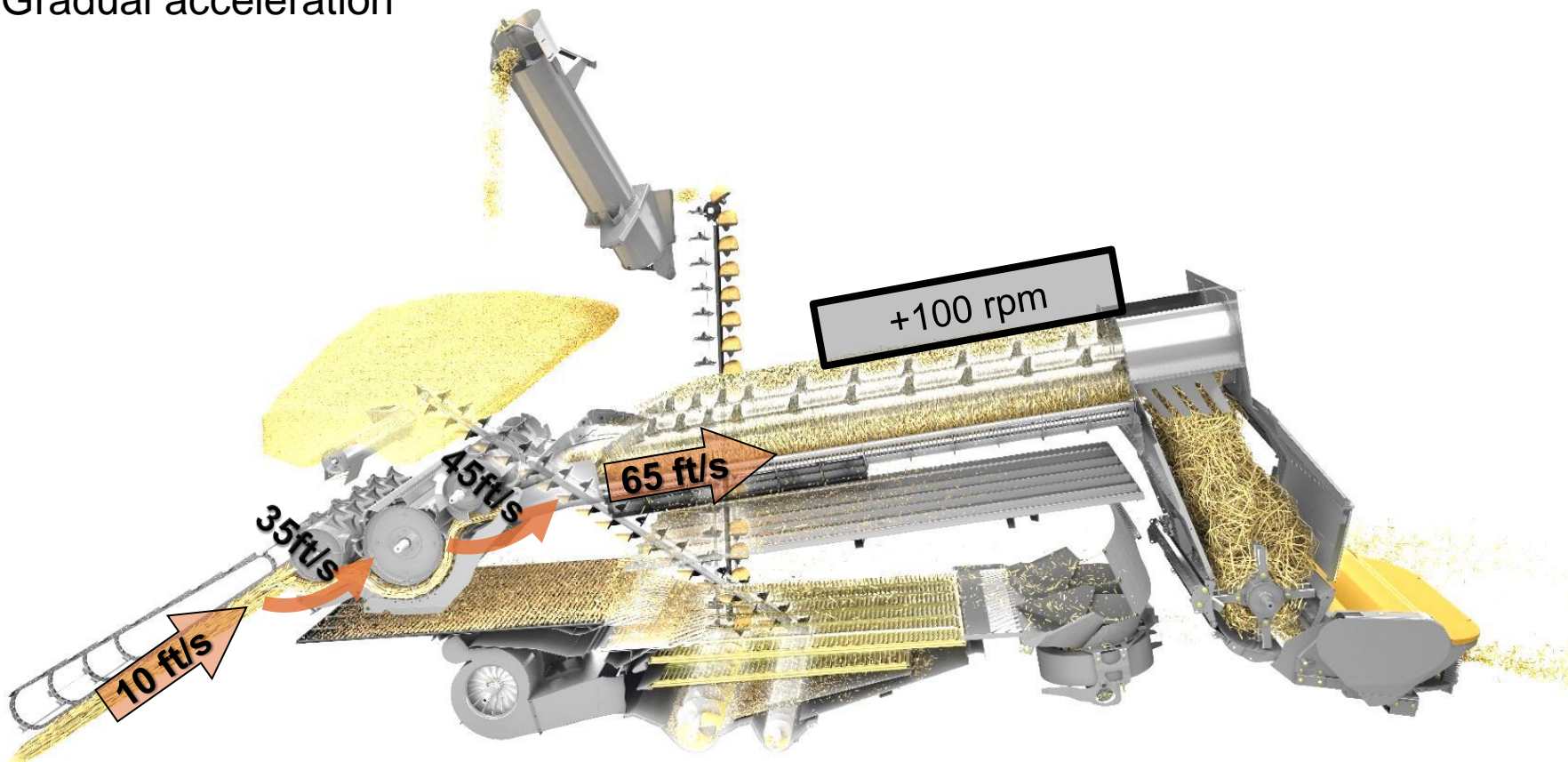

Rotor cover plates

- + Intensifies separation performance without drag on the crop flow
- + Helps optimize material flow to the cleaning system

Closed (in-cab adjustment)

- + Cleaner sample (less trash on sieves)
- Limits separation area (capacity)

Open (in-cab adjustment)

- + Maximum separation area
- Potential increased chaff load on sieves (more trash on sieves)

Clip on rotor cover plates (manual)

- + Clips on rotor grate to blank off area, if hydraulically actuated plates not available on machine (check machine configuration)
- + Secured via over-center latch

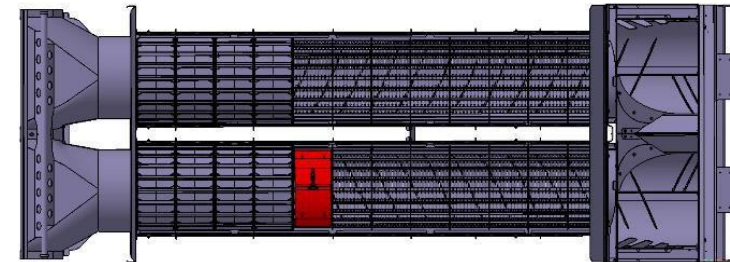
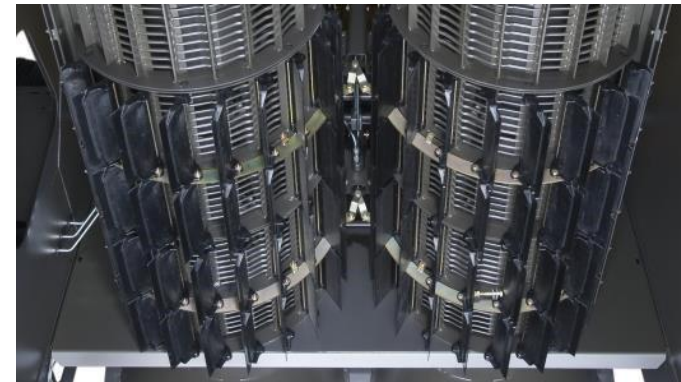

To order manual clip-on covers, contact:

- Syracuse Iron Works
- +1 (402) 269-2407
- Have machine model and serial number ready when ordering

Rotor grates: standard spaced wires
p/n: 792 155.2 (x-factory)

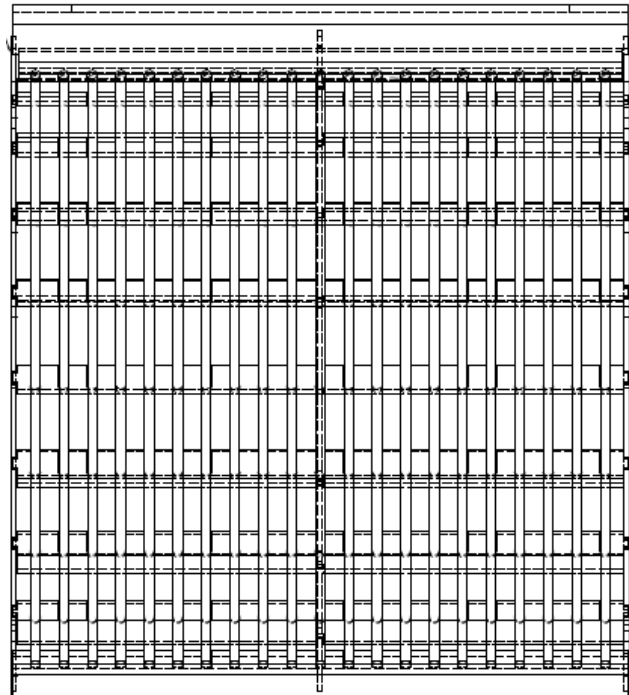

Rotor grates: wide spaced (HD rice)
p/n: 508 395.0 (spare parts only)

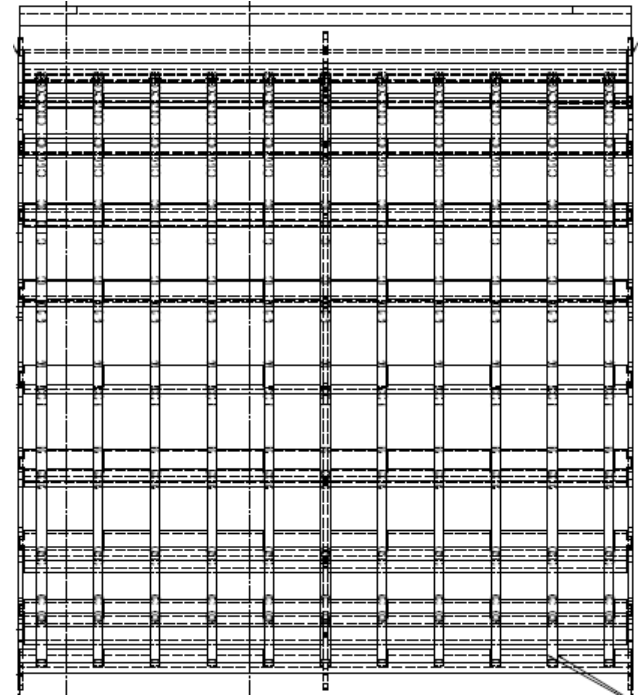

Upkeep

Floor pans can be easily removed through the front of the machine via the rock trap.

To ensure the cleaning system can run to maximize capacity, check floor pans regularly for:

- Dirt/debris build up
 - Build up can reduce amount of material the pan can move per stroke – which can affect machine capacity

Procedure:

1. Open and clean out rock trap
2. Remove three bolts holding door below rock trap and open door
3. Pull floor pans out through door
4. Clean pans with blunt object
 - Air hose
 - Water
 - Sharp objects can scratch poly and cause material to get stuck on pan



Fan speed

1. Too high

- + Very clean sample
- Potential for increased losses
- Potential for increased returns

2. Too low

- + Reduced sieve losses
- + Potential for decreased returns
- Potential for increased FM in sample



Upper sieve adjustment

1. Too tight

- + Very clean sample
- Potential for increased losses

2. Too open

- + Fewer losses (higher capacity)
- + Reduced returns possible
- More FM in sample

*Setting the upper sieve ALWAYS affects the performance of the lower sieve

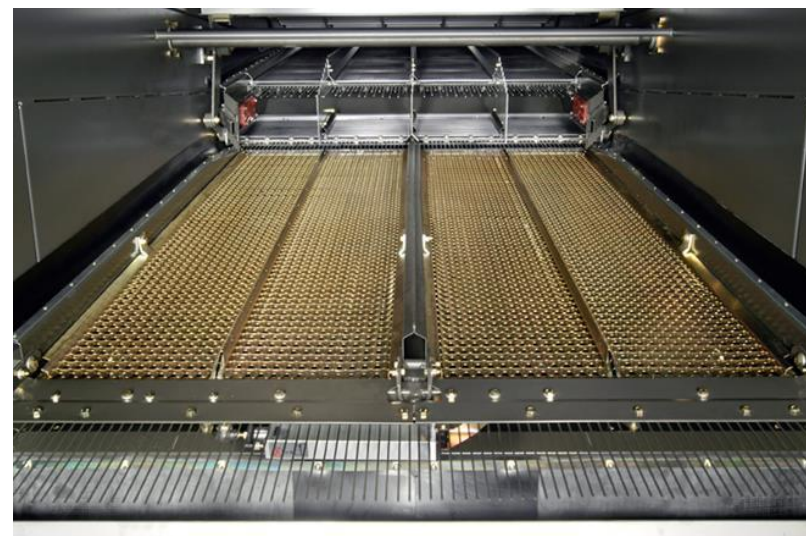

Tight upper sieve

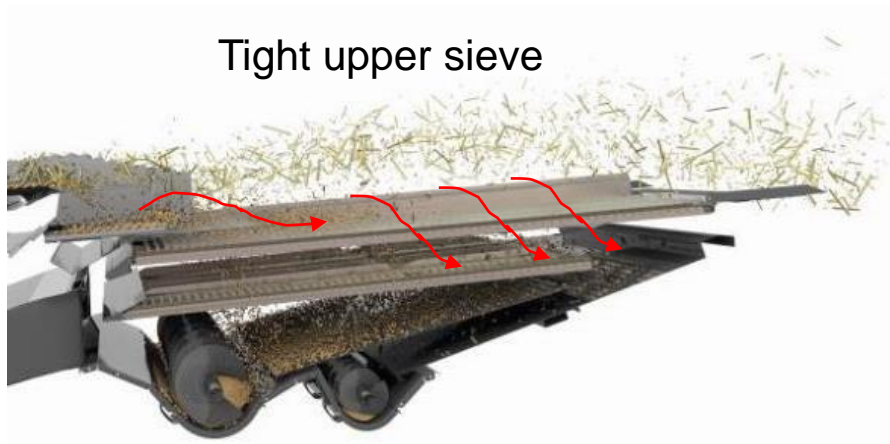

Open upper sieve

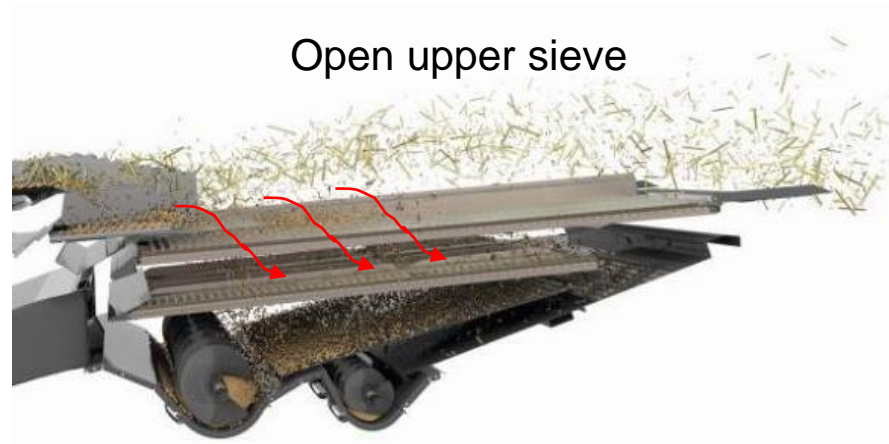

Lower sieve adjustment

1. Too tight

- + Cleaner sample
- Potential for increased returns

2. Too open

- + Fewer returns
- More FM in sample

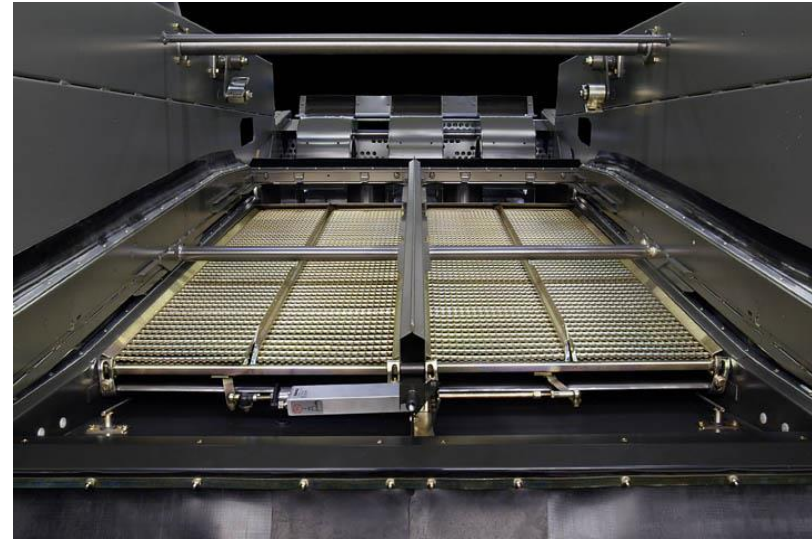

Tight lower sieve

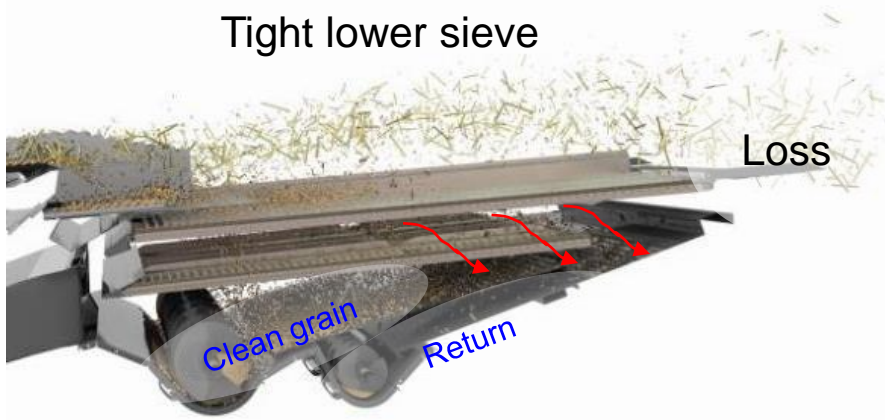

Open lower sieve

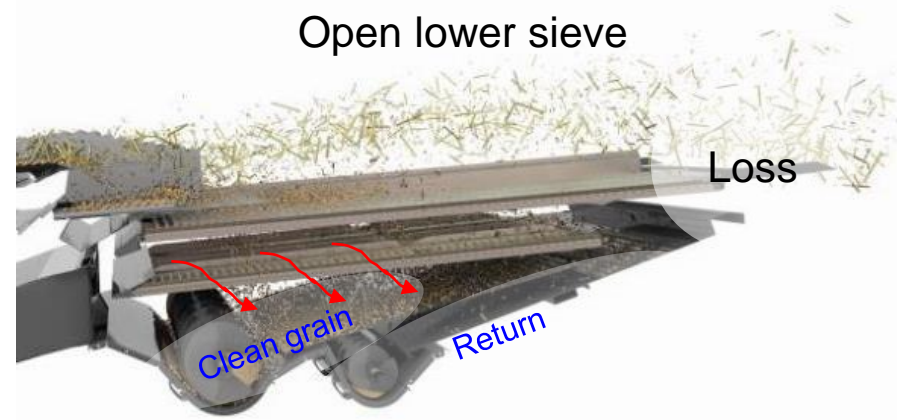

Sieve selection

1. Frog-mouth
2. TM6
3. Deep-tooth

Opening size

- Large – better capacity, less cleaning
- Small – less capacity, better cleaning

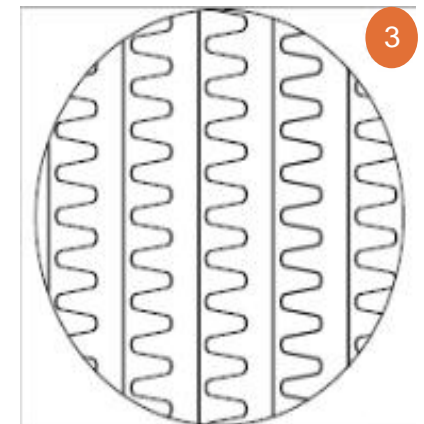
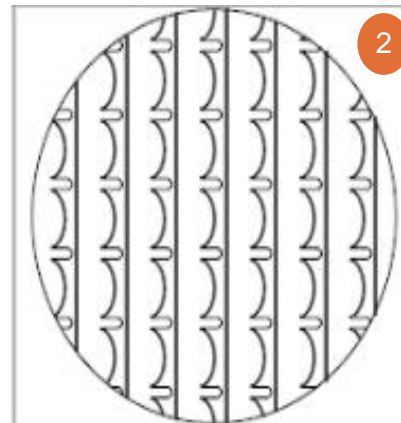
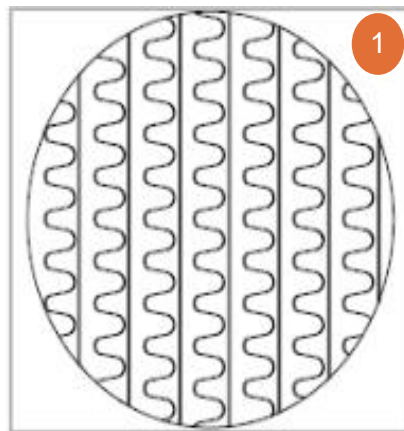

Standard frogmouth sieve

Small grains sieves without the airfoil effect of a TM6

Effective in:

- + Soybeans
- + Edibles
- + Sunflowers
- + Low yielding corn
- + Cereals
- + Small grains

Multi-purpose sieve

- Limited opening has potential to reduce capacity in high yielding crops

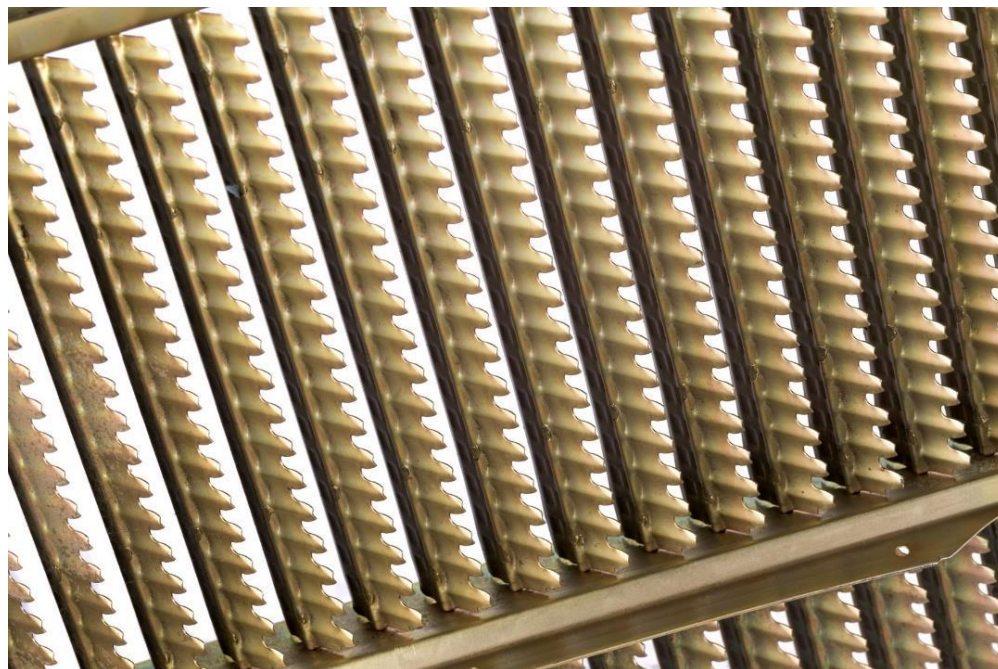

Part	Standard chassis	Wide chassis	Quantity
Upper sieve	91022572	91022596	2
Lower sieve	756 462.0	756 465.0	2

TM6 sieve

Premium sieves (upper and lower) for small grains and canola

Effective in:

- + Soybeans
- + Edibles
- + Sunflowers
- + Cereals
- + Small grains
- + Micro seeds

Not recommended for use in corn

- Fibers and silks have the potential to hair-pin on the foils and may cause the sieve to plug

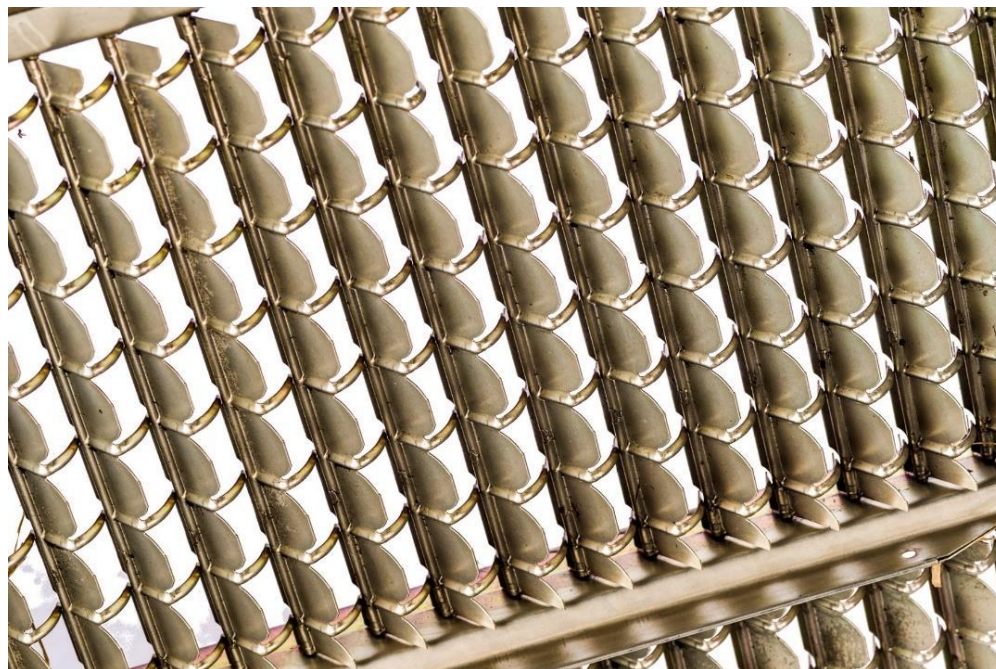

Part	Standard chassis	Wide chassis	Quantity
Upper sieve	91022574	91022598	2
Lower sieve	756 446.0	756 448.0	2

Deep tooth sieve

Premium corn sieve

Effective in:

- + Corn
- + Soybeans
- + Edibles
- + Sunflowers
- + Cereals

Not recommended for use in small grain

- Wide opening can increase large particles in grain sample

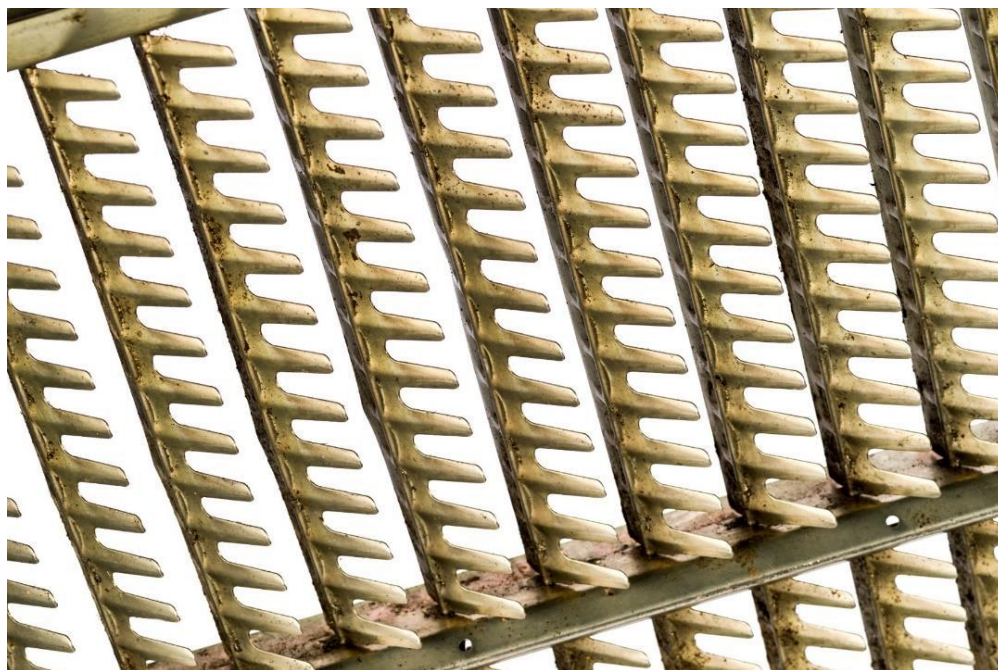

Part	Standard chassis	Wide chassis	Quantity
Upper sieve	91022576	91022600	2
Lower sieve	756 474.0	756 475.0	2

CB22

Bottom sieve for corn/bean machines

Effective in:

- + Corn
- + Soybeans
- + Edibles
- + Sunflowers
- + Cereals

**only available as a bottom sieve*



Part	Standard chassis	Wide chassis	Quantity
Upper sieve	N/A	N/A	
Lower sieve	1818 483.1	1818 484.1	2

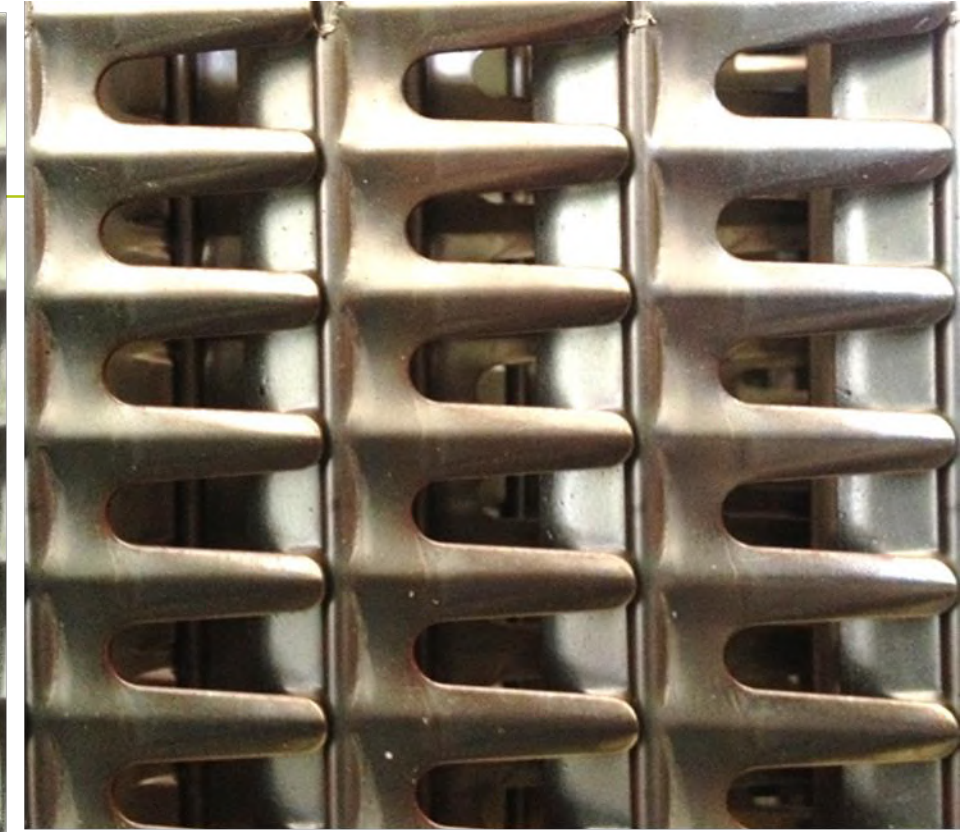
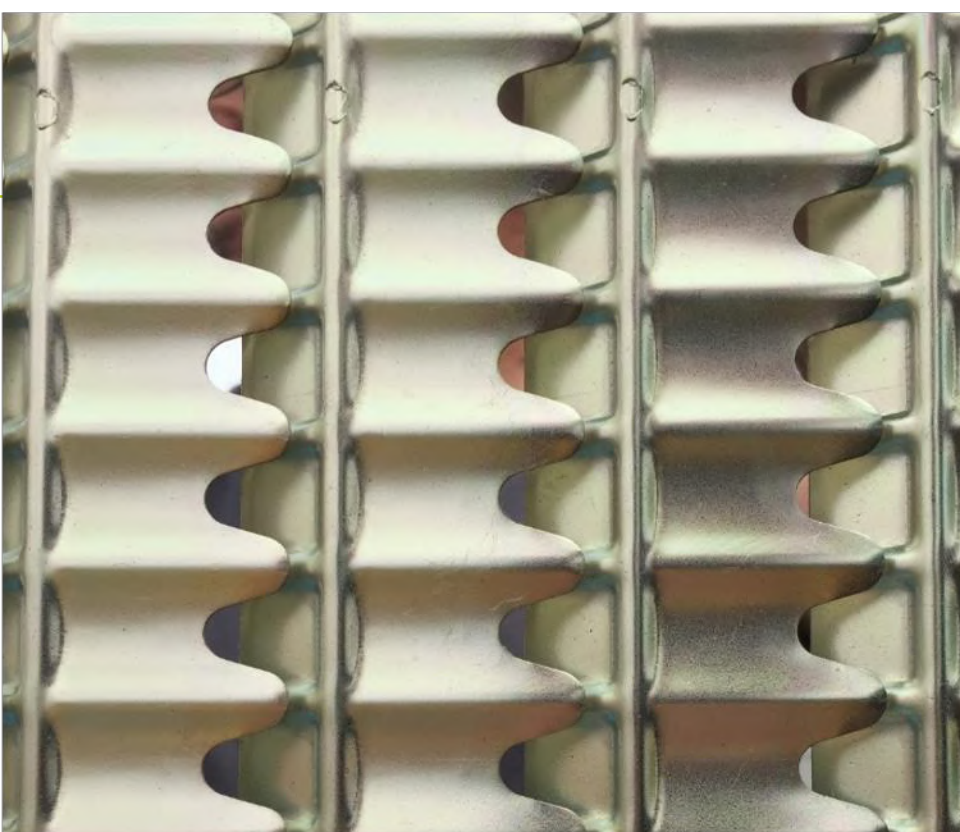

High / low speed adjustments

Chopper drive

- Standard chopper
- TURBO CHOP
- PRO CHOP

High speed

- Large pulley driving small pulley
- Small grains, soybeans, rice

Low speed

- Small pulley driving large pulley
- Corn

Procedure

1. Push de-tension lever forward to release tension from drive belt
2. Switch belt onto correct pulley for application
3. Release de-tension lever to reapply tension to belt

* De-tension assembly standard on corn machines

* Order from parts for small grains machine

De-tension assembly	Part number
De-tension lever	00 0061 759 2
Lever knob	00 0631 759 2
Lever bolt	00 0238 125 0
Lever nut	00 0238 132 0
De-tension guide plate	00 0352 809 2
Guide plate bolt (2)	00 0237 453 0
Guide plate washer (2)	00 0239 394 1

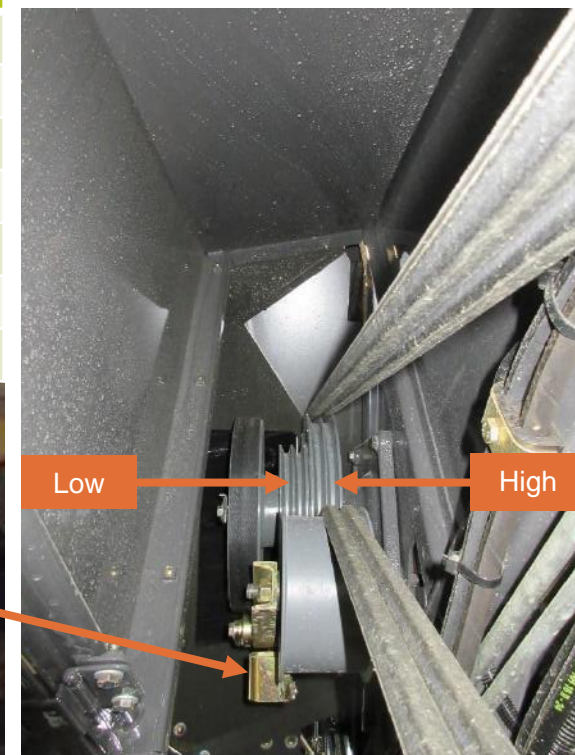
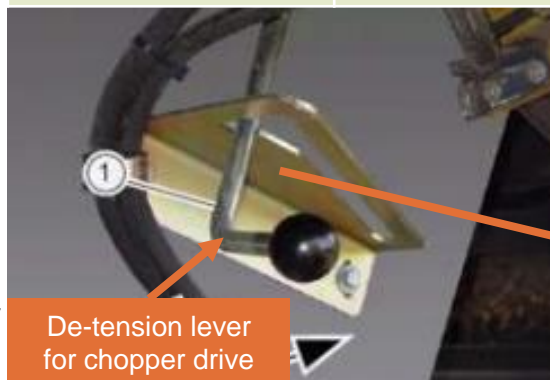

Chopper drive speed must be opposite of spinner drive speed

High / low speed adjustments

Spinner drive

- TURBO CHOP
- PRO CHOP

High speed

- If chopper is in low speed
- Large pulley driving small pulley
- Corn

Low speed

- If chopper is in high speed
- Small pulley driving large pulley
- Small grains, soybeans, rice

Procedure

1. Tighten de-tension nut up against spring tensioner to release tension on drive belt
2. Switch belt onto correct pulley for application
3. Loosen de-tension to tension belt

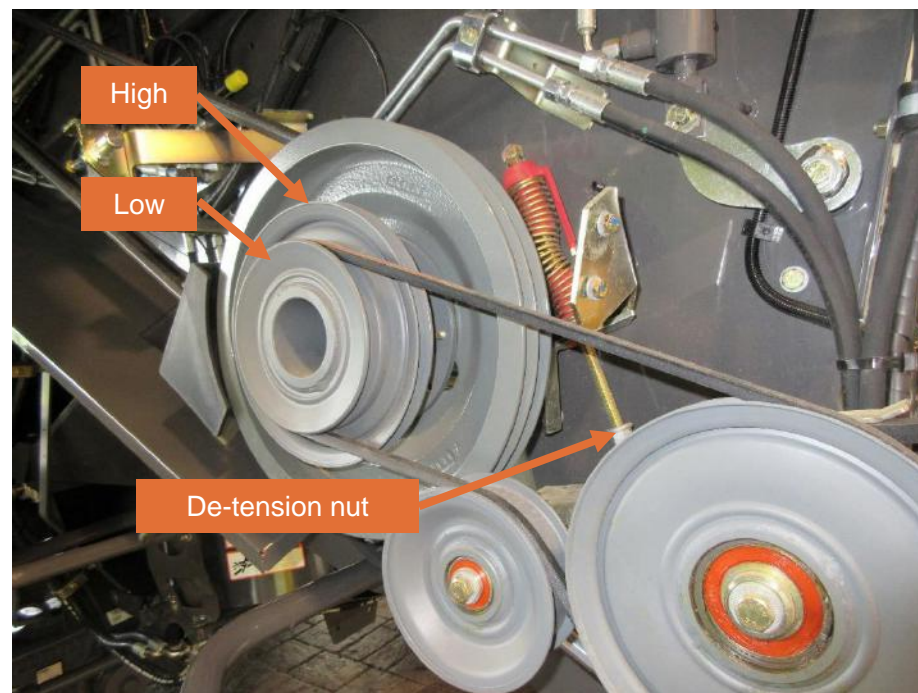

Spinner drive speed must be opposite of chopper drive speed

Stationary knives A

3-position knife bank

- + Engaged by a lever or hydraulically from the cab

Available:

- Standard Chopper
- TURBO CHOP
- PRO CHOP

Engaged

- + Smaller residue size
- Increased horsepower load

Disengaged

- + Decreased horsepower load
- Larger residue size

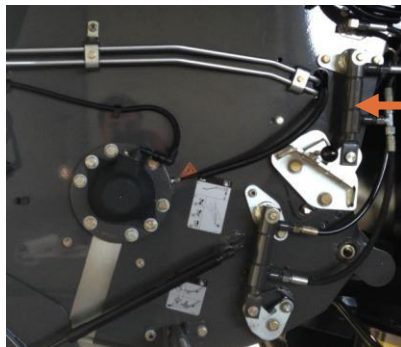

Hydraulic engagement

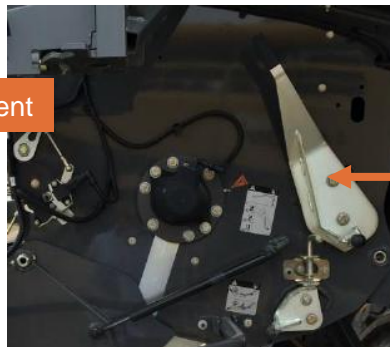

Lever engagement



Friction plate **B**

Speed bump in chopper chamber

- + Causes the crop to engage more of the rotary knives for increased chopping action
- + Engaged by a lever or hydraulically from the cab

Available:

- TURBO CHOP
- PRO CHOP

Engaged

- + Smaller residue size
- + Can use in place of or conjunction with stationary knives
- Increased horsepower load

Disengaged

- + Decreased horsepower load
- Larger residue size

Hydraulic engagement

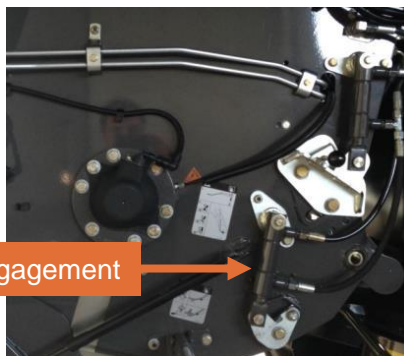

Lever engagement

